

CAIXA PARA BATERIAS

BATTERY BOX

CAIXA PARA BATERIAS BATTERY BOX

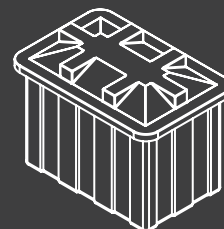

PT FICHA TÉCNICA

EN DATASHEET



100% Reciclável
100% Recyclable



Proteção UV
UV protection

Características

- ☑ Insensibilidade à corrosão
- ☑ Estanquidade total

Material

- ☑ Polietileno Linear

Characteristics

- ☑ Insensitivity to corrosion
- ☑ Total tightness

Material

- ☑ Linear Polyethylene

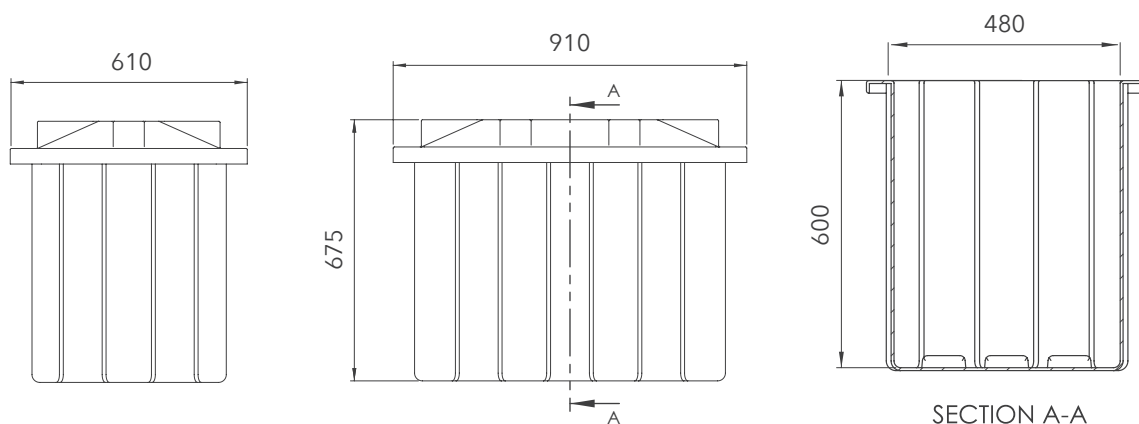

REF.	COMPRIMENTO LENGTH	LARGURA WIDTH	ALTURA HEIGHT	LARGURA A-A A-A WIDTH	ALTURA A-A A-A HEIGHT	CAPACIDADE VOLUME	COR COLOR
Mod. Pequ. AMB800	910 mm	610 mm	675 mm	480 mm	600 mm	10kg	● RAL 1021

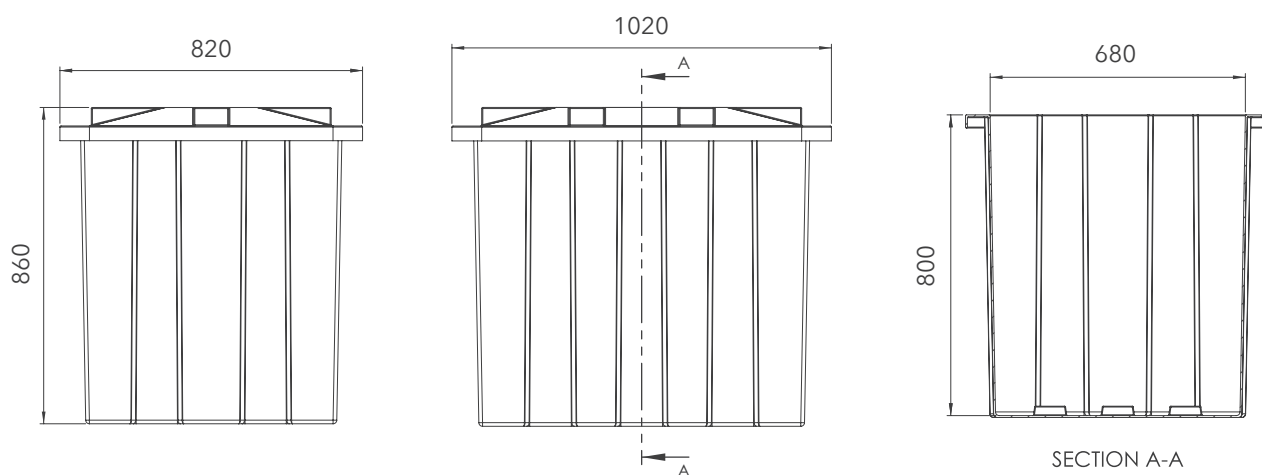

REF.	COMPRIMENTO LENGTH	LARGURA WIDTH	ALTURA HEIGHT	LARGURA A-A A-A WIDTH	ALTURA A-A A-A HEIGHT	CAPACIDADE VOLUME	COR COLOR
Mod. Grande AMB801	1020 mm	820 mm	860 mm	680 mm	800 mm	20 kg	● RAL 1021